

V-25-25L and V-25-30L

V-Series Single Shaft High Speed Dissolver

MorehouseCowles V-series standard designs deliver the ultimate dispersion, de-agglomeration and dissolving technology. Its reliable, versatile, and economical design is built for decades of dependable operation. With standard safety features, these dissolvers are designed to help prevent injury without sacrificing performance and reliability.

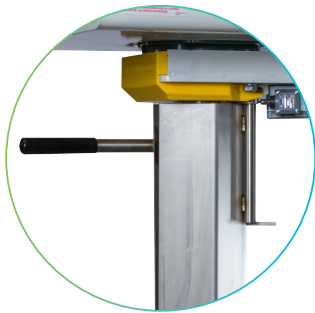

Shaft guard limit switch



Hydraulic lift limit switch

CAPACITY:	- 150 to 330 gallon batches
MATERIAL VISCOSITY:	- Up to 50,000 cP
MOTOR:	- 25 hp or 30 hp - 1800 RPM, 230/460 volt, 60 Hz, 3 phase - TEFC Class I, Division 1, Group D (explosion proof) - Inverter duty motor 4:1 ratio - Premium efficiency
LIFT:	- Air-over-oil operated lift - 48" stroke, heavy-duty industrial cylinder - ASME reservoir
DRIVE:	- V-belt and sheave - Variable speed via Variable Frequency Drive (VFD/inverter) controlled
SHAFT:	- 303 stainless steel
SPEED RANGE:	- 1400 RPM (5135 FPM) at 60 Hz approx.
IMPELLER BLADE:	- 14" diameter genuine Cowles high-shear - 304 stainless steel

INSTRUMENTATION:	- Digital tachometer in a NEMA 7 (explosion proof) housing
UTILITIES REQUIRED:	- Electrical power 3 phase - Clean, dry, compressed air at 100 psi/g
SPECIAL FEATURES:	- Energy efficient - Variable speed - 270° rotation to service multiple tanks - Designed for easy, less costly maintenance
SAFETY FEATURES:	- Tank holder with limit switch – will not run if tank is not in place - Lift height limit switch – will not run if unit is raised above 12" - Shaft guard with limit switch with clamp design for easy cleaning – will not run if guard is not closed - Drive guard – covers belts and pulley
CONSTRUCTION:	- 303/304 stainless steel, all wetted parts - Non-wetted parts: carbon steel painted with white two-part epoxy

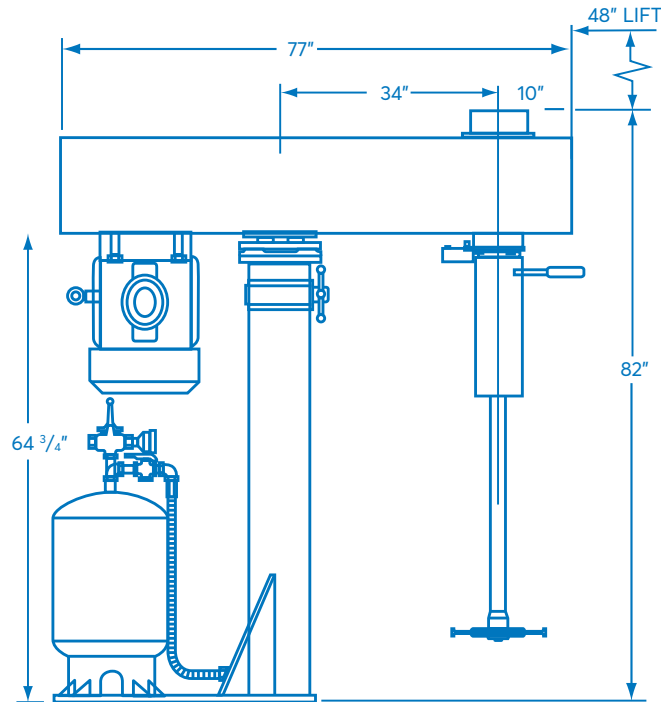

OPTIONAL UPGRADES:

LIFT

1. Custom lift height and stroke
2. Electric, hydraulic lift in lieu of air-over-oil system
3. Platform-bearing on lift assembly – allows the operator to manually rotate the mixing shaft side-to-side with very little force
4. Pneumatic power-driven rotator – allows the unit to rotate between two tanks remotely using a joystick control

DRIVE

1. Variable Frequency Drive (VFD/ Inverter), NEMA 1 (non-explosion proof, for non-hazardous areas)
2. Operator Basic Pendant Remote Control, NEMA 7 (explosion proof) includes:
 - On/Off button
 - Red Mushroom Stop button
 - Potentiometer for speed control
3. Operator Master Control Remote Control, NEMA 7 (explosion proof) includes:
 - On/Off button
 - Red Mushroom Stop button
 - Potentiometer for speed control
 - Digital ammeter
 - Digital tachometer
4. Drive Cabinet, NEMA 12 (dust proof) for protection against environment and easy installation of inverter

SPEED

1. Custom speed range for various dissolving applications

IMPELLER BLADE

1. POLY-PELLER™ blade in lieu of high-shear blade – no additional cost
2. Full line of specialty impeller blades

CONSTRUCTION

1. 316L stainless steel wetted parts
2. All stainless steel

LID

1. Tank dust cover (lid) with gas spring and bellows to raise lid and lift together

Made in the USA

For more information, visit [morehousecowles.com](https://www.morehousecowles.com) or contact MorehouseCowles experts today at sales@morehousecowles.com or +1 (909) 627 7222.