

V-12-1.0 and V-12-2.0

V-Series Single Shaft High Speed Dissolver

MorehouseCowles V-series standard designs deliver the ultimate dispersion, de-agglomeration and dissolving technology. Its reliable, versatile, and economical design is built for decades of dependable operation. With standard safety features, these dissolvers are designed to help prevent injury without sacrificing performance and reliability.



	V-12-1.0	V-12-2.0
CAPACITY:	- 1/4 to 1 gallon batches	- 1 to 5 gallon batches
MATERIAL VISCOSITY:	- Up to 15,000 cP	- 15,000 cP
MOTOR:	1 hp - 3600 RPM, 230/460 volt, 60 Hz, 3 phase - TEFC only (Non-explosion proof) - Inverter duty motor 4:1 ratio - Premium efficiency	2 hp - 3600 RPM, 230/460 volt, 60 Hz, 3 phase - TEFC Class I, Division 1, Group D (explosion proof) - Inverter duty motor 4:1 ratio - Premium efficiency
LIFT:	- Air operated lift - 10" stroke, heavy-duty industrial cylinder	- Air operated lift - 14" stroke, heavy-duty industrial cylinder
DRIVE:	- V-belt and sheave - Variable speed via Micro-Variable Frequency Drive (VFD/inverter)	- V-belt and sheave - Variable speed via Variable Frequency Drive (VFD/inverter)
SHAFT:	- High strength 17-4SS heat treated	- 304 stainless steel
SPEED RANGE:	- 7600 RPM (4000 FPM) at 60 Hz approx.	- 5000 RPM (5240 FPM) at 60 Hz approx.
IMPELLER BLADE:	- 2" diameter genuine Cowles high-shear - 304 stainless steel	- 4" diameter genuine Cowles high-shear - 304 stainless steel
INSTRUMENTATION:	- Digital RPM readout from micro drive	- Digital tachometer in NEMA 7 (explosion proof) housing
UTILITIES REQUIRED:	- Electrical power single phase 115 volt input - Clean, dry, compressed air at 100 psi/g	- Electrical power 3 phase - Clean, dry, compressed air at 100 psi/g
SPECIAL FEATURES:	- Energy efficient - Variable speed plug-n-play - Single position - Pot spring loaded cover, holder and locator - Designed for easy maintenance	- Energy efficient - Variable speed - Single position - Designed for easy, less costly maintenance - Tank holder
SAFETY FEATURES:	- Lift height limit switch – will not run if unit is raised above 1.50" - Shaft enclosure with bellows - Drive guard – covers belt and pulleys - Power input disconnect from micro drive for maintenance	- Lift height limit switch – will not run if unit is raised above 4" - 6-1/2" shaft guard - Drive guard – covers belts and pulley
CONSTRUCTION:	- 17-4ph/304 stainless steel for all wetted parts - Non-wetted parts: carbon steel painted with white two-part epoxy	- 303/304 stainless steel, all wetted parts - Non-wetted parts: carbon steel painted with white two-part epoxy

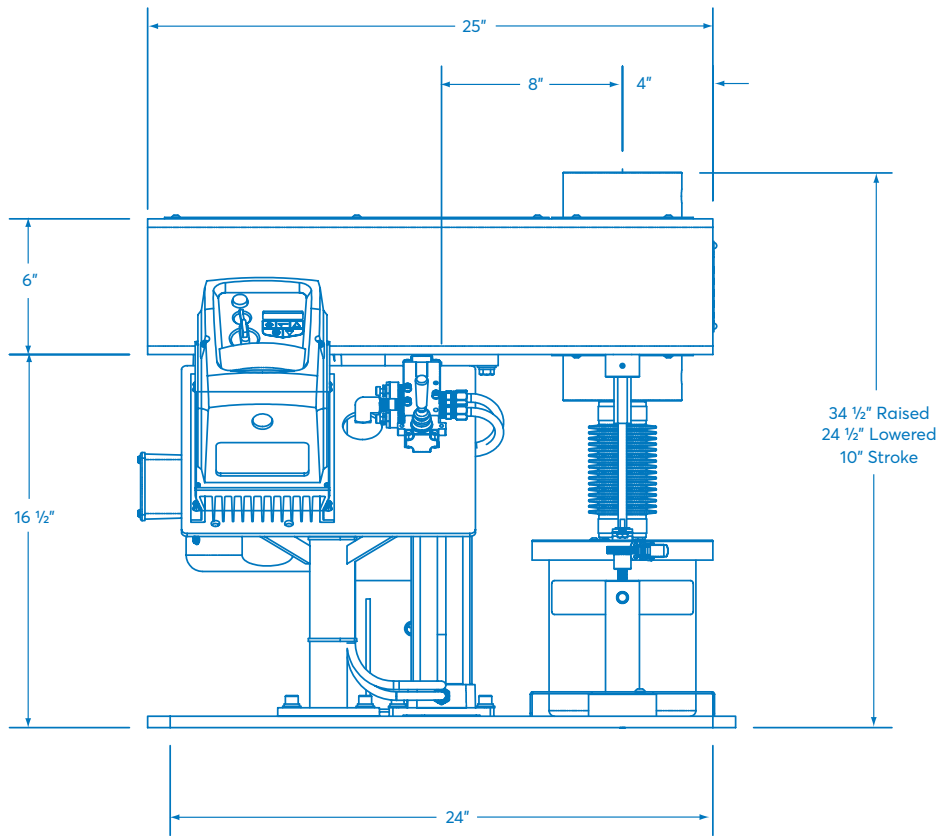

OPTIONAL UPGRADES:

DRIVE

1. Variable Frequency Drive (VFD/ Inverter), NEMA 1 (non-explosion proof, for non-hazardous areas)
2. **V-12-2 only** - Operator Basic Pendant Remote Control, NEMA 7 (explosion proof) includes:
 - On/Off button
 - Red Mushroom Stop button
 - Potentiometer for speed control
3. **V-12-2 only** - Operator Master Control Remote Control, NEMA 7 (explosion proof) includes:
 - On/Off button
 - Red Mushroom Stop button
 - Potentiometer for speed control
 - Digital ammeter
 - Digital tachometer
4. **V-12-2 only** - Drive Cabinet, NEMA 12 (dust proof) for protection against environment and easy installation of inverter

SPEED

1. Custom speed range for various dissolving applications

IMPELLER BLADE

1. POLY-PELLER™ blade in lieu of high-shear blade – no additional cost
2. Full line of specialty impeller blades

CONSTRUCTION

1. 316L stainless steel wetted parts
2. All stainless steel

LID

1. **V-12-2 only** - Spring loaded tank dust cover (lid) with bellows.

CONTROL STAND

1. **V-12-2 only** - For mounting NEMA 7 remote control pendant and pneumatic lift control valve

Made in the USA

For more information, visit [morehousecowles.com](https://www.morehousecowles.com) or contact MorehouseCowles experts today at sales@morehousecowles.com or +1 (909) 627 7222.